

DM DESERT MACHINERY
آليات الصحراء

Perkins Denyo AIRMAN Cummins LINZ ELECTRIC LEROY SOMER DSE ComAp
ABB LS Schneider Electric

AIRMAN GENERATOR

25 KVA (20 KW)

(JAP)



SPECIFICATIONS

OF

DIESEL GENERATOR SET

Model: SDG25S-3B1

AIRMAN[®]

HOKUETSU INDUSTRIES CO., LTD.

8TH FLOOR SHINJUKU SAN-EI BLDG.
22-2, NISHISHINJUKU 1-CHOME, SHINJUKU-KU,
TOKYO 160-0023 JAPAN
TEL; 81-3-3348-7284
FAX; 81-3-3348-7289

1. GENERAL

1-1 Structure

The generator set is designed direct coupling with brushless type of generator and diesel engine. The A.C. generator and diesel engine are mounted on the robust steel skid frame with radiator, fuel tank and control panel.

It is provided large doors on both sides of unit and constructed to have easy daily maintenance works.

Moreover, it is put large inhalation of air and discharge duct on and make lining for sound absorption inside the unit. It is also installed large discharge silencer to have good effect of soundproof.

All control devices, operating switches and meters are positioned on a control panel so that it is easy to operate.

1-2 Applicable Standards

The generator is designed, manufactured and tested in accordance with the following standards.

JIS	Japanese Industrial Standards
JEM	Standard of the Japan Electrical Manufacturers' Association
JEC	Standard of the Japanese Electrotechnical Committee

1-3 Site Conditions

(Unless otherwise specified the generator shall be able to keep the performances.)

Temperature	-15°C ~ +40°C
Humidity	below 85%
Altitude	below 1,000m (Above sea level)

1-4 Standard condition

The rated output is assumed to be a value in a standard JIS atmospheric condition.

Atmospheric temp.	25 °C
Humidity	30%
Atmospheric pressure	100kPa

1-5 Strong point

The third exhaust gas restriction

Super low noise approval (less than 92 dB/sound power level)

Dual voltage switch equipment

(200/220(50Hz/60Hz) 3 Phase and 400/440(50Hz/60Hz) 3 phase)

Leakage protection device standard equipment

Electric governor standard equipment

2. Specification

2-1 Dimensions & Weight

Model name	SDG25S-3B1
Overall length	Approx. 1,550 mm
Overall width	Approx. 700 mm
Overall height	Approx. 980 mm
Net dry mass	Approx. 610 kg
Operating mass	Approx. 680 kg

Allowable inclination of the machine below 5°

2-2 Capacity for Water, Oil, and Battery

Cooling water capacity	6.9	Liters
Fuel tank capacity	68	Liters
Lubricating oil capacity	9.7	Liters
Battery	80D26R	12V

2-3 Painting Color

External painting	Peaceful Green Kawakami SP-189
External painting of frame	Charcoal Gray Kansai paint NS-388-X31

3. Generator

3-1 A.C. Generator

		Dual Voltage type	
3P, 4W	Output	20/25 kVA (16/20 kW)	
	Voltage	200 / 220 V	400(380) / 440 V
	Current	57.7/65.6 A	28.9(30.4) / 32.8 A
Frequency		50/60 Hz	
No. of phases		3phase 4wire	
No. of poles		4	
Power factor		80%	
Type		Revolving field brushless type	
Rated revolution		1,500/1,800 min ⁻¹ (1,500/1,800 rpm)	
Class of insulation		Class F	
Class of rating		Continuous	
Driving system		Direct coupled to engine	

3-2 Rise of Temperature

When the ambient temperature is 40°C, the temperature of the following components shall be within the limit of the following figure.

Armature winding	105K (105deg) (Insulation class F)
Field winding	110K (110deg) (Insulation class F)
Bearing	40K (40deg)

3-3 Dielectric test

An approximately sine wave form voltage of commercial frequency in the following table shall be applied for one minute.

Appropriate if no trouble takes place in such test.
(not include AVR)

Between armature winding and earth	AC 1500V (one minute)
Between field winding and earth	AC 1500V (one minute)
Between control panel and earth	AC 1500V (one minute)

3-4 Steady state voltage regulation

The steady state voltage regulation shall be maintained between $\pm 0.5\%$ from full load to no load.

4. Diesel Engine

4-1 Specification

Maker	KUBOTA
Model	V2403-K3A
Type	Water-cooled 4 cycle, swirl-chamber
No. of cylinder	4
Bore dia. × stroke	87 mm × 102.4 mm
Total displacement	2.434 L (2,434 cc)
Compression ratio	24.4 : 1
Rated output	19.1 kW / 1,500 min ⁻¹ (26PS / 1,500rpm) 23.7 kW / 1,800 min ⁻¹ (32.2 PS / 1,800rpm)
Dry weight	204 kg
Charging generator	12V, 30 A
Starter motor	12V, 1.4 kW
Air cleaner	Dry type
Diesel fuel	Cetane Value over 45
Lubricating oil	CD class, SAE 10W-30

4-2 Fuel consumption (reference value)

Frequency	50 / 60 Hz
Full load	5.2 / 6.5 L/Hr
75% load	4.0 / 5.0 L/Hr

5 Protection

	Engine stop	Breaker trip	Warning lamp on * 1	Warning lamp on * 2	Actuating
Engine oil pressure	○		○	○	Engine oil pressure drop operating pressure : lower than 0.05MPa
Engine water temp.	○		○	○	Engine water temp. rise operating temp. : 115°C
Overcurrent, Short circuit		○			Overcurrent and Short circuit
Leakage		○	○		Leakage or short circuit occur Actuating current 30mA
Battery	○		○	○	Not charging
Air filter Clogged			○		Airfilter cloggeed
Overspeed	○			○	Engine speed rise abnormally operating speed : 2,070min ⁻¹
Abnormal of speed sensor	○			○	Sensor have trouble or wiring snapped
Abnormal of solenoid	○			○	Wiring of actuator snapped or short-circuit
Abnormal of water temp. sensor	○			○	Wiring of water temp. short-circuit
Short circuit of water temp. sensor	○			○	Signal wiring of temp. sensor was short-circuit
Snapping alternater L wire	○			○	L wiring of altenater snapped
Overvoltage	○			○	Voltage riase abnormally operating voltage : 18 V

The above devices are equipped to protect from each trouble during operation.
The mark ○ means to function for each kind of trouble.

*1 : Warning lamp will turn on when abnormal condtion occur.

*2 :Abnormal indicater lamp will blink when device to inspect failure work.

Blinking pattern will be indicated trouble situation.

6 Control Panel

6-1 Control panel for A.C. generator

1) Voltmeter	1pc.
2) Ammeter	1pc.
3) Frequency meter	1pc.
4) Voltage regulator	1pc.
5) Leakage relay	1pc.
6) Circuit breaker	1pc.
7) Output indicator lamp	1pc.
8) Frequency selection switch	1pc.
9) Starter switch	1pc.

6-2 Control panel for engine

1) Speed control switch	1pc.			
2) Glow lamp/warning lamp	1pc.			
3) Coolant temperature gauge	1pc.			
4) Fuelmeter with hourmeter	1pc.			
5) Panel light	1pc.			
6) Panel light switch	1pc.			
※ Warning lamps	<table border="0"> <tr> <td style="font-size: 4em; vertical-align: middle;">(</td> <td> <ul style="list-style-type: none"> ▪ Engine oil pressure drop ▪ Coolant temperature rise ▪ Not charging ▪ Air filter clogging ▪ Abnormal indicating </td> <td style="font-size: 4em; vertical-align: middle;">)</td> </tr> </table>	(<ul style="list-style-type: none"> ▪ Engine oil pressure drop ▪ Coolant temperature rise ▪ Not charging ▪ Air filter clogging ▪ Abnormal indicating)
(<ul style="list-style-type: none"> ▪ Engine oil pressure drop ▪ Coolant temperature rise ▪ Not charging ▪ Air filter clogging ▪ Abnormal indicating)		
	1 set			

9. Wiring Diagram

9.1 Generator Wiring Diagram

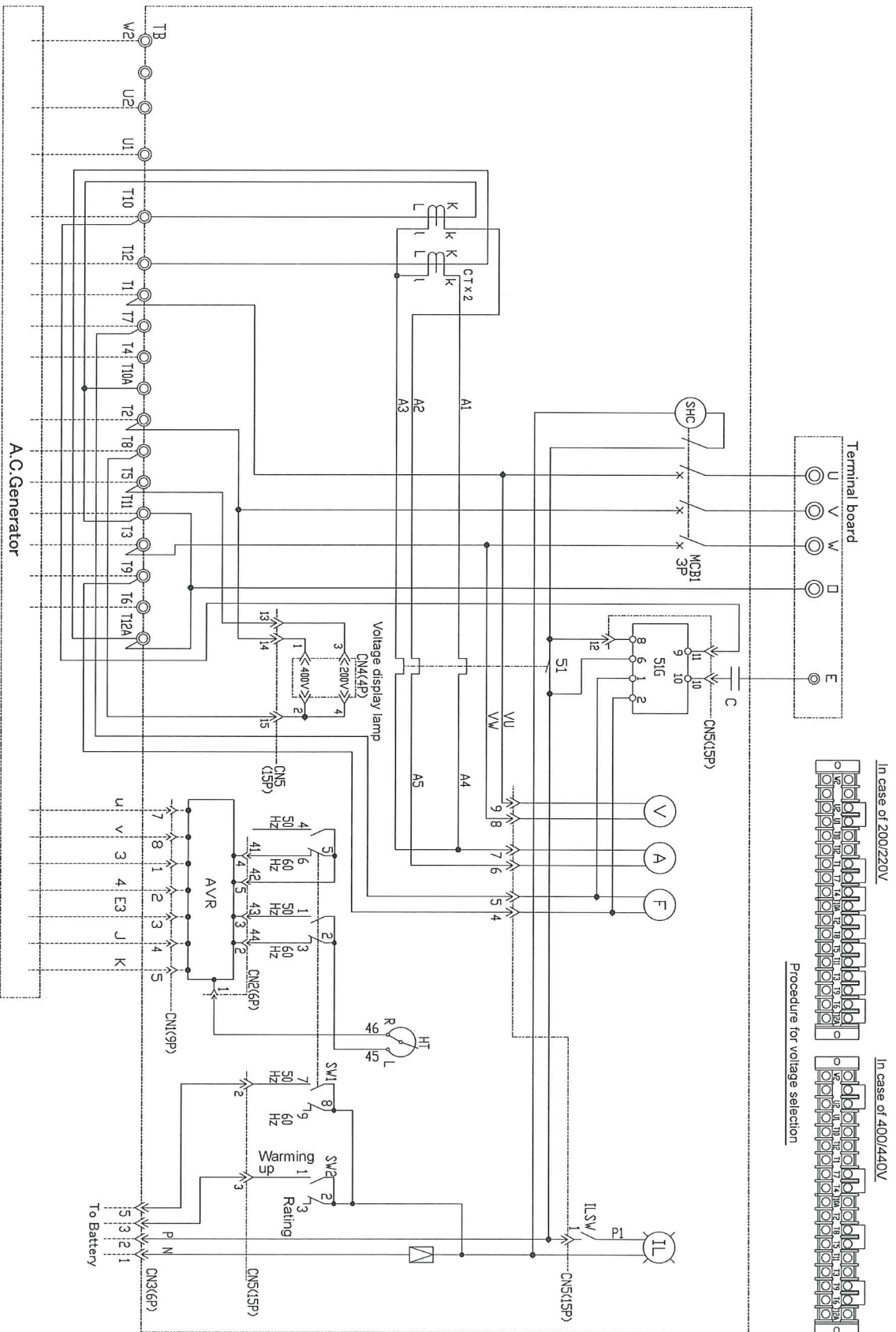

9. Wiring Diagram

9.2 Engine Wiring Diagram

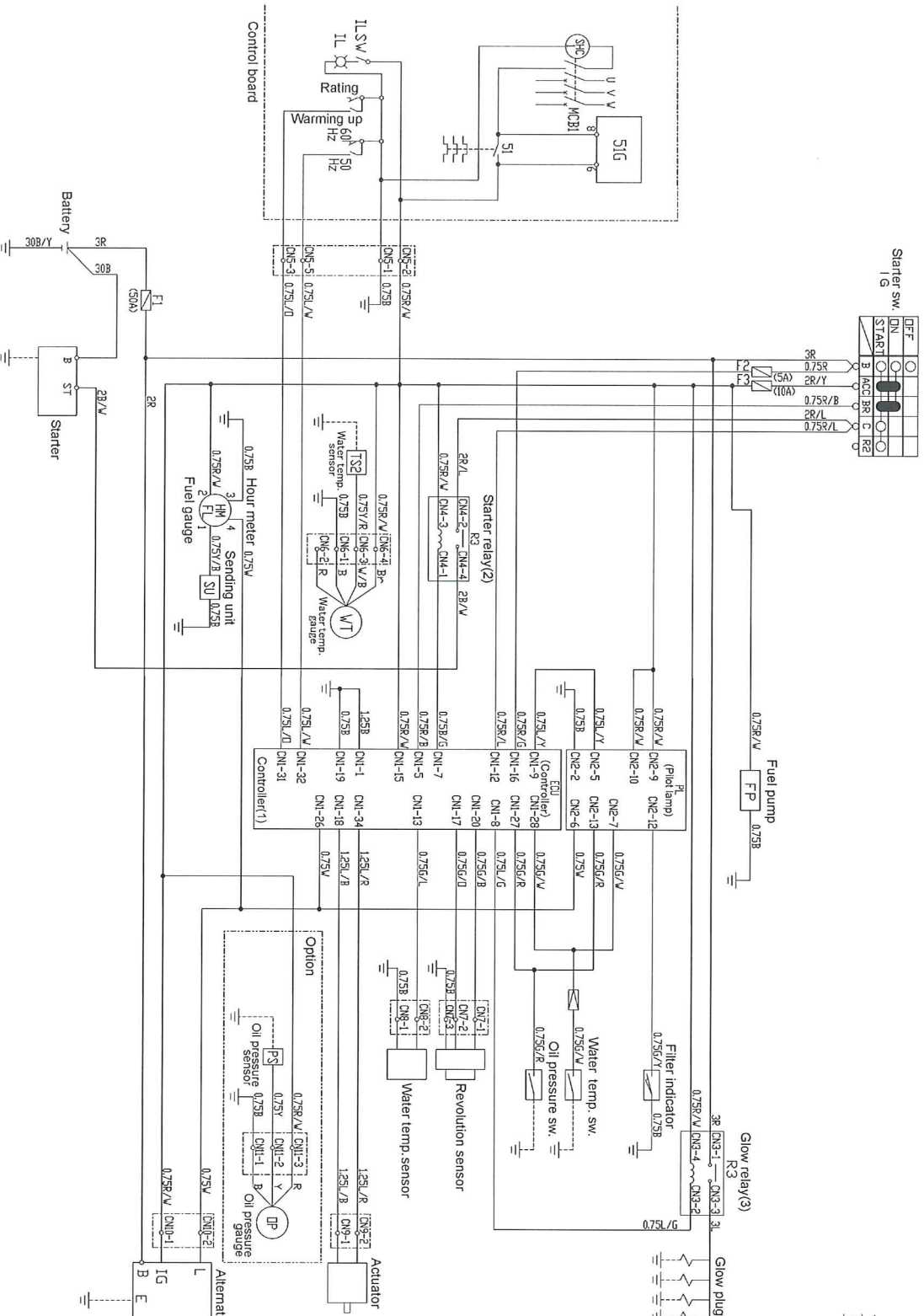

Connector terminal arrangement
The following arrangement is seen from
the side of the connector inserting port.