

**DM** DESERT MACHINERY  
آليات الصحراء

Perkins Denyo AIRMAN LINZ LEROY SOMER DSE ComAp  
ABB LS Schneider Electric

# PERKINS GENERATOR

197 KVA ( 157 KW )

(UK)



# 1100 Series 1106A-70TAG3 Diesel Engine – Electropak

163.9 kWm prime power / 179.8 kWm standby power @ 1500 rev/min  
 180.5 kWm prime power / 199.7 kWm standby power @ 1800 rev/min

Building upon Perkins proven reputation within the power generation industry, the 1100 Series range of Electropak engines now fit even closer to customers needs.

In the world of power generation success is only gained by providing more for less. With the 1106A-70TAG Perkins has engineered even higher levels of reliability, yet lowered the cost of ownership.

1100A units are designed for territories that do not require compliance to EPA or EU emissions legislation. These engines are assembled around optimal, efficient manufacturing processes with state-of-the-art technology. They are built to provide the exact power solution for customers who sell their applications into lesser regulated countries.

Focusing on our common platform theme, changes to engine envelope dimensions and connection points have been kept to a minimum.



## Dependable power

- The Perkins 1106A-70TAG3 delivers up to 200 kVA standby at 50 Hz and 175 kWe at 60 Hz, providing greater productivity through an improved power to weight ratio.
  - This world-class power density has been achieved in a 7 litre engine, using a mechanical fuel injection system; making this engine robust for all markets, with the ability to cope with the variation of fuel qualities around the world.
- The 1106A has been designed for excellent load acceptance to ensure your facility is powered quickly at all conditions.

## Low operating costs

- Service intervals are set at 500 hours as standard.
- Perkins provides comprehensive warranty cover for two years (up to 3,000 hours), with three years on major engine components.
- A low usage warranty package is also available.

## World class product support

- Through an experienced global network of distributors and dealers, fully trained engine experts deliver total service support around the clock, 365 days a year. They have a comprehensive suite of web based tools at their finger tips, covering technical information, parts identification and ordering systems, all dedicated to maximising the productivity of your engine.
- Perkins actively pursues product support excellence by insisting our distribution network invest in their territory to provide you with a consistent quality of support across the globe.
- Throughout the entire life of a Perkins engine, we provide access to genuine OE specification parts giving 100% reassurance that you receive the very best in terms of quality for lowest possible cost... wherever your Perkins powered machine is operating in the world.

Engine Speed (rev/min)	Type of Operation	Typical Generator Output (Net)		Engine Power			
				Gross		Net	
		kVA	kWe	kWm	bhp	kWm	bhp
1500	Prime Power	180.0	144.0	163.9	219.7	157.7	211.5
	Standby (maximum)	200.0	160.0	179.8	241.1	175.2	234.9
1800	Prime Power	196.9	157.5	180.5	242.0	172.5	231.3
	Standby (maximum)	218.8	175.0	199.7	268.0	191.7	257.0

# 1100 Series 1106A-70TAG3 Diesel Engine – ElectropaK

163.9 kWm prime power / 179.8 kWm standby power @ 1500 rev/min

180.5 kWm prime power / 199.7 kWm standby power @ 1800 rev/min

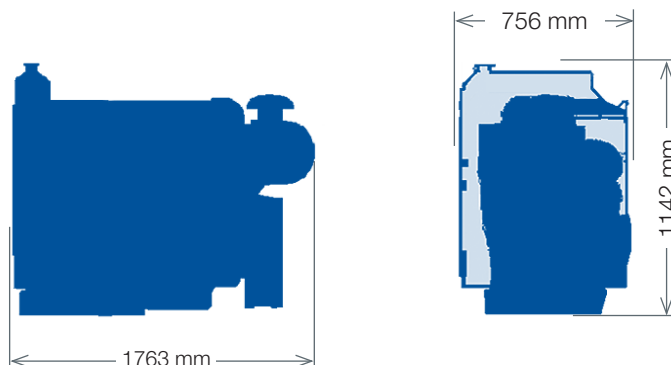

## Engine specification

- Tropical radiator pipes and guards
- Flywheel housing
- Flywheel and starter ring
- Oil filters
- Starter motor
- Air cleaners and brackets
- Lubricating oil sump
- Alternator
- Induction manifolds
- Exhaust manifolds
- Fuel filter
- Cold start aid
- Engine mountings

## Engine data

Number of cylinders .....	Vertical in-line 6 cylinder
Bore and stroke.....	105 x 135 mm (4.13 x 5.31 in)
Displacement .....	7.01 litres (428 in <sup>3</sup> )
Aspiration .....	Turbocharged aftercooled
Cycle.....	4 stroke
Combustion system.....	Direct injection
Compression ratio .....	16:1
Engine rotation .....	Anti-clockwise viewed on flywheel
Cooling system.....	Liquid
Total lubrication capacity.....	16.5 litres (4.36 US gal)
Total coolant capacity .....	21 litres (5.5 US gal)
Dimensions – Length .....	1763 mm (69.4 in) with air cleaner
Width .....	756 mm (29.8 in)
Height .....	1142 mm (45 in)
Dry weight .....	788 kg (1737 lbs)

Final weight and dimensions will depend on completed specification

Photographs are for illustrative purposes only and may not reflect final specification.

All information in this document is substantially correct at time of printing and may be altered subsequently.  
Publication No. PN3055/08/13 Produced in England  
©2013 Perkins Engines Company Limited

## Perkins Engines Company Limited

Peterborough PE1 5FQ  
United Kingdom  
Telephone +44 (0)1733 583000  
Fax +44 (0)1733 582240  
[www.perkins.com](http://www.perkins.com)



THE HEART OF EVERY GREAT MACHINE



**TAL 046**

## **Low Voltage Alternator - 4 pole**

180 to 365 kVA - 50 Hz / 225 to 438 kVA - 60 Hz  
Electrical and mechanical data

**LEROY-SOMER**<sup>™</sup>

***Nidec***  
All for dreams

## Adapted to needs

The TAL alternator range is designed to meet the needs of general applications such as prime power and stand-by.

## Compliant with international standards

The TAL range complies with international standards and regulations: IEC 60034 and derivative.

The range is designed, manufactured and marketed in an ISO 9001 and 14001 environment.

## Electrical design

- Class H insulation
- Shunt excitation
- Low voltage winding:
  - Three-phase 50 Hz: 380V - 400V - 415V - 440V / 220V - 230V - 240V
  - 60 Hz: 380V - 416V - 440V - 480V / 220V - 208V - 240V
- 6-terminal plates in 6-wire version or suitable for 12-wire option
- Optimized performance

## Robust design

- Compact and rugged assembly to withstand engine vibrations
- Steel frame
- Cast iron flanges and shields
- Single bearing design to be suitable with most diesel engines
- Sealed for life bearing
- Direction of rotation: clockwise and counterclockwise without derating



## Excitation and regulation system suited to the application

	Excitation system				Regulation options		
	AVR	Shunt	AREP	PMG	ULc/us	Remote voltage potentiometer	C.T. for paralleling
Three-phase 6-wire	R150	Standard				√	
	R180		Standard	Standard		√	√
	R450		Option	Option	√	√	√
Three-phase 12-wire*	R250	Standard			√	√	
	R180		Standard	Standard		√	√
	R450		Option	Option	√	√	√

√ : Possible option      \*with larger terminal box

## Compact terminal box

- Easy access to AVR and terminals
- Standard terminal box with possibility of mounting measurement CTs
- Possibility of current transformer for parallel operation

## Environment and protection

- IP Code IP 23
- Standard winding protection for non-harsh environments with relative humidity ≤ 95%

## Available options

- Three-phase 12-wire with 9-terminal plates
- AREP or PMG excitation
- ULc/us
- Customized painting
- Space heaters
- Droop kit for alternator paralleling
- Stator sensors
- Winding 8 optimized for three-phase 380V - 416 V / 60 Hz
- Winding protection for harsh environments and relative humidity greater than 95% (system 2 - 4): for TAL 046 H apply a derating coefficient of 0.97

# TAL 046 - 180 to 365 kVA - 50 Hz / 225 to 438 kVA - 60 Hz

## General characteristics

Insulation class	H	Excitation system 6-wire	SHUNT	AREP / PMG
Winding pitch	2/3 (wind.6S - 6-wire / wind.6 - 12-wire)	AVR type	R150	R180
Number of wires	6-wire (12-wire option)	Excitation system 12-wire (option)	SHUNT	AREP / PMG
Protection	IP 23	AVR type	R250	R180
Altitude	≤ 1000 m	Voltage regulation (*)	± 1 %	
Overspeed	2250 R.P.M.	Total Harmonic Distortion THD (**) in no-load	< 2.5 %	
Air flow (m³/s)	0.48	Total Harmonic Distortion THD (**) in linear load	< 5 %	
Air flow (m³/s)	0.58	Waveform: NEMA = TIF (**)	< 50	
AREP Short-circuit current = 2.7 In: 5 second		Waveform: I.E.C. = THF (**)	< 2%	

(\*) Steady state (\*\*) Total harmonic distortion between phases, no-load or on-load (non-distorting)

## Ratings 50 Hz - 1500 R.P.M.

kVA / kW - P.F. = 0.8																				
Duty / T° C	Continuous / 40 °C					Continuous / 40 °C					Stand-by / 40 °C				Stand-by / 27 °C					
Class / T° K	H / 125° K					F / 105° K					H / 150° K				H / 163° K					
Phase	3 ph.			1 ph.		3 ph.			1 ph.		3 ph.		1 ph.		3 ph.			1 ph.		
Y	380V	400V	415V	440V		380V	400V	415V	440V		380V	400V	415V	440V		380V	400V	415V	440V	
Δ	220V	230V	240V		230V	220V	230V	240V		230V	220V	230V	240V		230V	220V	230V	240V		230V
YY (*)	200V		220V			200V		220V			200V		220V			200V		220V		
ΔΔ (*)				230V					230V					230V					230V	
<b>TAL 046 A</b> kVA	180	<b>180</b>	180	171	108	164	<b>164</b>	164	156	98	191	<b>191</b>	191	181	114	200	<b>200</b>	200	188	119
kW	144	144	144	137	86	131	131	131	125	78	153	153	153	145	91	160	160	160	150	95
<b>TAL 046 B</b> kVA	200	<b>200</b>	200	190	120	182	<b>182</b>	182	173	109	212	<b>212</b>	212	201	127	220	<b>220</b>	220	209	132
kW	160	160	160	152	96	146	146	146	138	87	170	170	170	161	102	176	176	176	167	106
<b>TAL 046 C</b> kVA	230	<b>230</b>	230	219	138	209	<b>209</b>	209	199	126	244	<b>244</b>	244	232	146	253	<b>253</b>	253	241	152
kW	184	184	184	175	110	167	167	167	159	101	195	195	195	186	117	202	202	202	193	122
<b>TAL 046 D</b> kVA	240	<b>250</b>	250	238	150	218	<b>228</b>	228	217	137	254	<b>265</b>	265	252	159	264	<b>275</b>	275	262	165
kW	192	200	200	190	120	175	182	182	174	110	204	212	212	202	127	211	220	220	210	132
<b>TAL 046 E</b> kVA	275	<b>275</b>	275	261	165	250	<b>250</b>	250	238	150	292	<b>292</b>	292	277	175	303	<b>303</b>	303	287	182
kW	220	220	220	209	132	200	200	200	190	120	234	234	234	222	140	242	242	242	230	146
<b>TAL 046 F</b> kVA	290	<b>300</b>	300	285	180	264	<b>273</b>	273	259	164	307	<b>318</b>	318	302	191	319	<b>330</b>	330	314	198
kW	232	240	240	228	144	211	218	218	207	131	246	254	254	242	153	255	264	264	251	158
<b>TAL 046 G</b> kVA	325	<b>325</b>	325	309	195	296	<b>296</b>	296	281	177	345	<b>345</b>	345	328	207	360	<b>360</b>	360	340	215
kW	260	260	260	247	156	237	237	237	225	142	276	276	276	262	166	288	288	288	272	172
<b>TAL 046 H</b> kVA	350	<b>365</b>	365	347	210	318	<b>332</b>	332	316	191	371	<b>387</b>	387	368	223	385	<b>400</b>	400	382	231
kW	280	292	292	278	168	255	266	266	253	153	297	310	310	294	178	308	320	320	306	185

(\*) 12-wire option

## Ratings 60 Hz - 1800 R.P.M.

kVA / kW - P.F. = 0.8																				
Duty / T° C	Continuous / 40 °C					Continuous / 40 °C					Stand-by / 40 °C				Stand-by / 27 °C					
Class / T° K	H / 125° K					F / 105° K					H / 150° K				H / 163° K					
Phase	3 ph.			1 ph.		3 ph.			1 ph.		3 ph.		1 ph.		3 ph.			1 ph.		
Y	380V	416V	440V	480V		380V	416V	440V	480V		380V	416V	440V	480V		380V	416V	440V	480V	
Δ	220V	240V		240V		220V	240V		240V		220V	240V		240V		220V	240V		240V	
YY (*)	208V		220V		240V	208V		220V		240V	208V		220V		240V	208V		220V		240V
ΔΔ (*)				240V					240V					240V					240V	
<b>TAL 046 A</b> kVA	180	195	210	<b>225</b>	120	164	177	191	<b>205</b>	109	191	207	223	<b>239</b>	127	200	215	230	<b>250</b>	132
kW	144	156	168	180	96	131	142	153	164	87	153	166	178	191	102	160	172	184	200	106
<b>TAL 046 B</b> kVA	200	215	230	<b>250</b>	132	182	196	209	<b>228</b>	120	212	228	244	<b>265</b>	140	220	237	253	<b>275</b>	145
kW	160	172	184	200	106	146	157	167	182	96	170	182	195	212	112	176	190	202	220	116
<b>TAL 046 C</b> kVA	226	250	262	<b>288</b>	152	206	228	238	<b>262</b>	138	240	265	278	<b>305</b>	161	250	275	288	<b>316</b>	167
kW	181	200	210	230	122	165	182	190	210	110	192	212	222	244	129	200	220	230	253	134
<b>TAL 046 D</b> kVA	245	265	280	<b>313</b>	165	223	241	255	<b>285</b>	150	260	281	297	<b>332</b>	175	270	292	308	<b>344</b>	182
kW	196	212	224	250	132	178	193	204	228	120	208	225	238	266	140	216	234	246	275	146
<b>TAL 046 E</b> kVA	275	300	315	<b>344</b>	182	250	273	287	<b>313</b>	166	292	318	334	<b>365</b>	193	303	330	347	<b>378</b>	200
kW	220	240	252	275	146	200	218	230	250	133	234	254	267	292	154	242	264	278	302	160
<b>TAL 046 F</b> kVA	290	315	340	<b>360</b>	200	264	287	309	<b>328</b>	182	307	334	360	<b>382</b>	212	320	347	374	<b>400</b>	220
kW	232	252	272	288	160	211	230	247	262	146	246	267	288	306	170	256	278	299	320	176
<b>TAL 046 G</b> kVA	315	345	365	<b>406</b>	215	287	314	332	<b>369</b>	196	334	366	387	<b>430</b>	228	347	380	402	<b>447</b>	237
kW	252	276	292	325	172	230	251	266	295	157	267	293	310	344	182	278	304	322	358	190
<b>TAL 046 H</b> kVA	345	375	400	<b>438</b>	231	314	341	364	<b>399</b>	210	366	398	424	<b>464</b>	245	380	413	440	<b>480</b>	254
kW	276	300	320	350	185	251	273	291	319	168	293	318	339	371	196	304	330	352	384	203

(\*) 12-wire option

Efficiencies 400 V - 50 Hz (— P.F.: 0.8) (..... P.F.: 1)

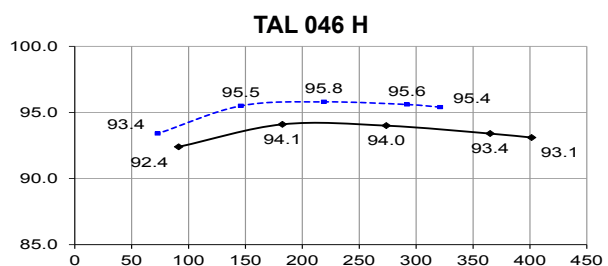
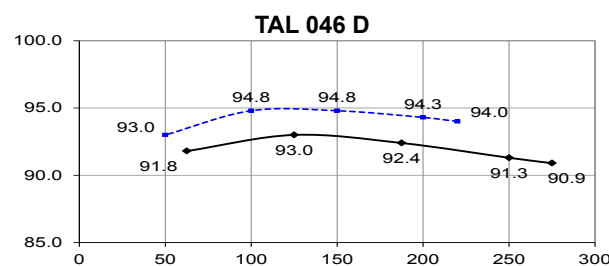
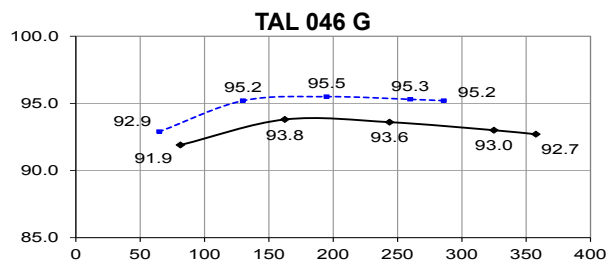
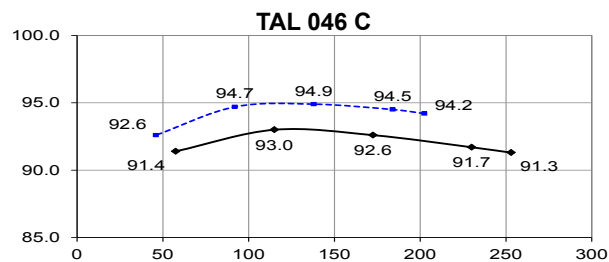
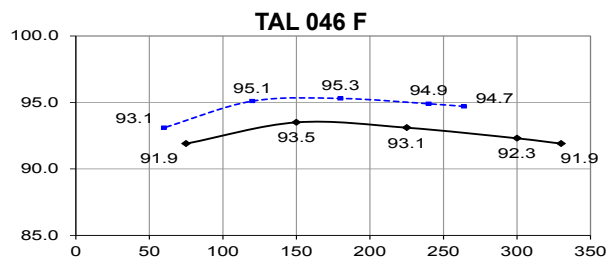
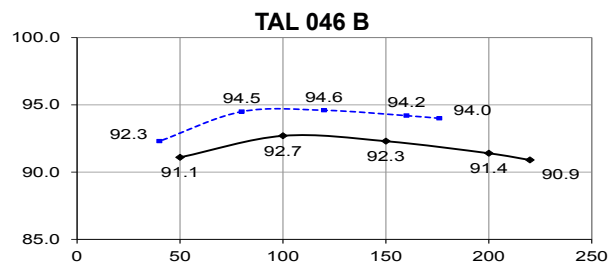
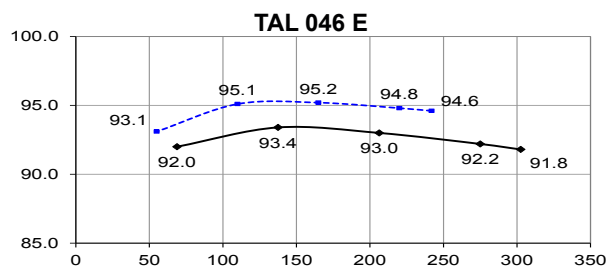
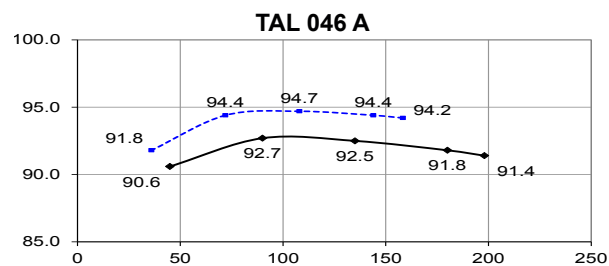

Reactances (%). Time constants (ms) - Class H / 400 V

	A	B	C	D	E	F	G	H
<b>Kcc</b> Short-circuit ratio	0.39	0.35	0.37	0.34	0.37	0.4	0.45	0.43
<b>Xd</b> Direct-axis synchro. reactance unsaturated	313	348	340	370	347	335	297	303
<b>Xq</b> Quadrature-axis synchro. reactance unsaturated	159	177	173	188	177	171	151	154
<b>T'do</b> No-load transient time constant	1956	1956	1983	1983	2018	2033	2072	2093
<b>X'd</b> Direct-axis transient reactance saturated	16	17.7	17.1	18.6	17.1	16.5	14.3	14.5
<b>T'd</b> Short-circuit transient time constant	100	100	100	100	100	100	100	100
<b>X''d</b> Direct-axis subtransient reactance saturated	12.8	14.2	13.7	14.9	13.7	13.2	11.4	11.6
<b>T''d</b> Subtransient time constant	10	10	10	10	10	10	10	10
<b>X''q</b> Quadrature-axis subtransient reactance saturated	16.4	18.2	17.4	18.9	17.2	16.4	14.1	14.2
<b>Xo</b> Zero sequence reactance	0.66	0.74	0.71	0.77	0.71	0.68	0.59	0.6
<b>X2</b> Negative sequence reactance saturated	14.6	16.2	15.6	16.9	15.5	14.8	12.8	12.9
<b>Ta</b> Armature time constant	15	15	15	15	15	15	15	15

Other class H / 400 V data

<b>io (A)</b> No-load excitation current SHUNT/AREP	0.95	0.95	1.01	1.01	1.1	1.1	1.06	1.06
<b>ic (A)</b> On-load excitation current SHUNT/AREP	3.4	3.72	3.84	4.14	3.99	3.64	3.63	3.63
<b>uc (V)</b> On-load excitation voltage SHUNT/AREP	48	52.4	37.4	40.2	55.6	46.2	42.1	41.9
<b>ms</b> Response time ( $\Delta U = 20\%$ transient)	500	500	500	500	500	500	500	500
<b>kVA</b> Start ( $\Delta U = 20\%$ cont. or $\Delta U = 30\%$ trans.) SHUNT*	311	311	372	371	444	445	556	618
<b>kVA</b> Start ( $\Delta U = 20\%$ cont. or $\Delta U = 30\%$ trans.) AREP*	374	376	446	447	533	534	667	741
<b>%</b> Transient $\Delta U$ (on-load 4/4) SHUNT - P.F.: 0.8 <sub>LAG</sub>	17.1	18.4	18	19.1	18	19.1	17.4	17.4
<b>%</b> Transient $\Delta U$ (on-load 4/4) AREP - P.F.: 0.8 <sub>LAG</sub>	15.1	16.2	15.8	16.8	16.2	17.2	17.3	15.4
<b>W</b> No-load losses	2977	2977	3297	3297	3625	4013	4541	4750
<b>W</b> Heat dissipation	12841	15040	16562	18869	18504	19800	19303	20484

\* P.F. = 0.6

Transient voltage variation 400 V - 50 Hz

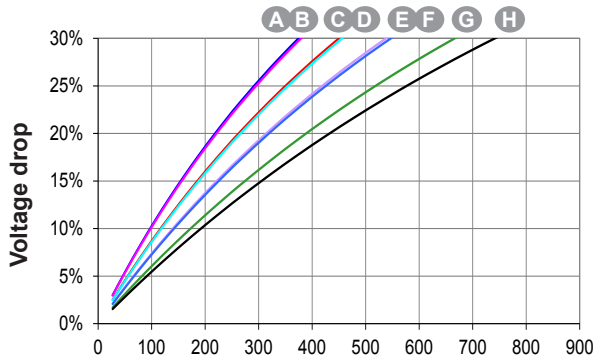

Phase loading (SHUNT) - kVA at P.F. = 0.8

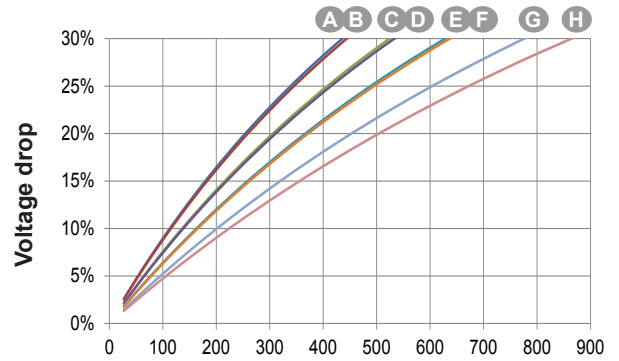

Phase loading (AREP) - kVA at P.F. = 0.8

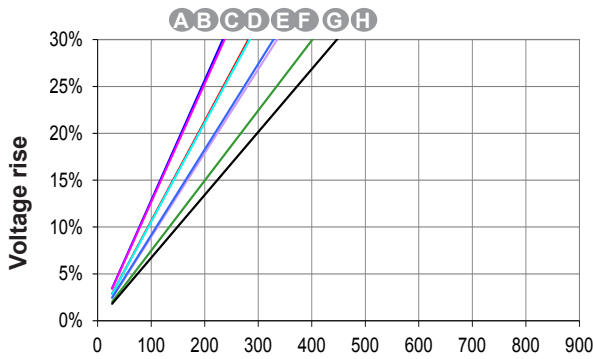

Load shedding (SHUNT) - kVA at P.F. = 0.8

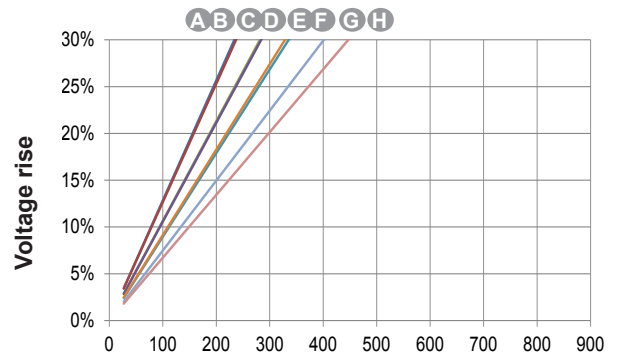

Load shedding (AREP) - kVA at P.F. = 0.8

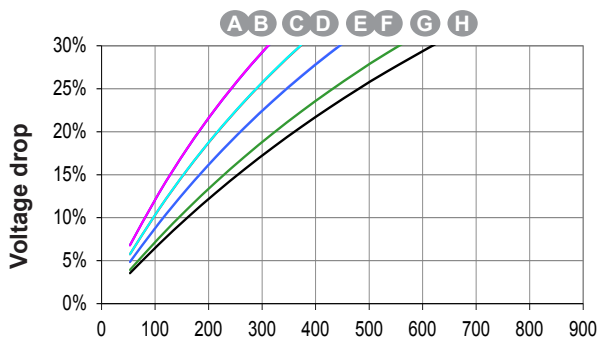

Motor starting (SHUNT)  
Locked rotor kVA at P.F. = 0.6

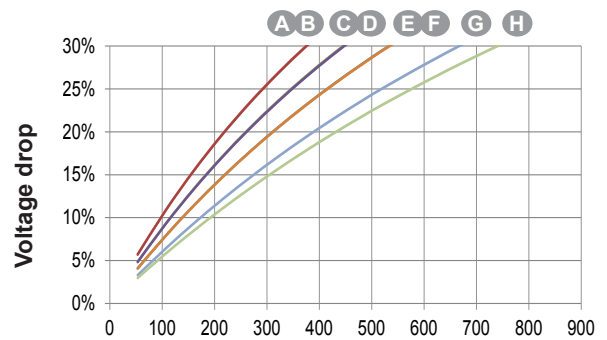

Motor starting (AREP)  
Locked rotor kVA at P.F. = 0.6

- 1) For a starting P.F. other than 0.6, the starting kVA must be multiplied by  $K = \text{Sine P.F.} / 0.8$
- 2) For voltages other than 400V (Y), 230V (Δ) at 50 Hz, then kVA must be multiplied by  $(400/U)^2$  or  $(230/U)^2$ .



**Efficiencies 480 V - 60 Hz (— P.F.: 0.8) (----- P.F.: 1)**

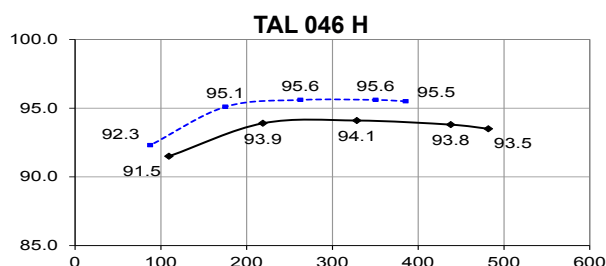
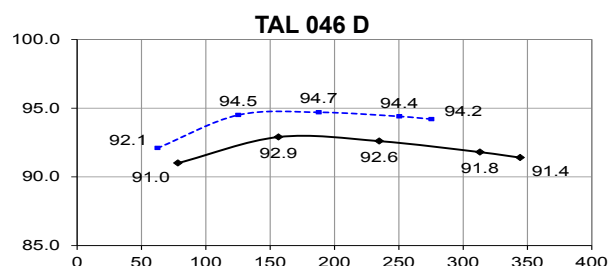
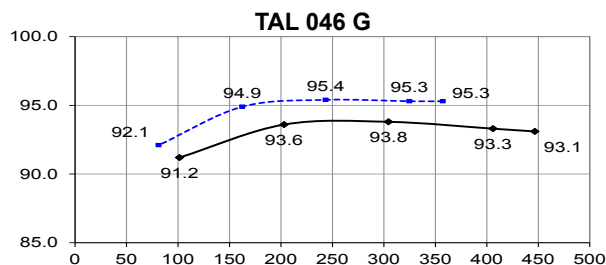
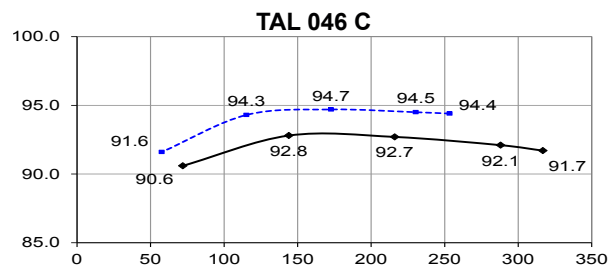
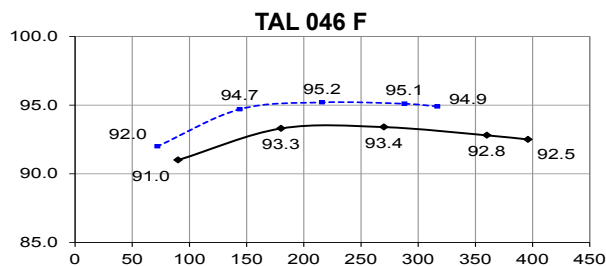
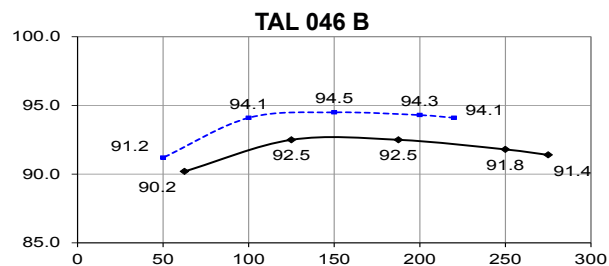
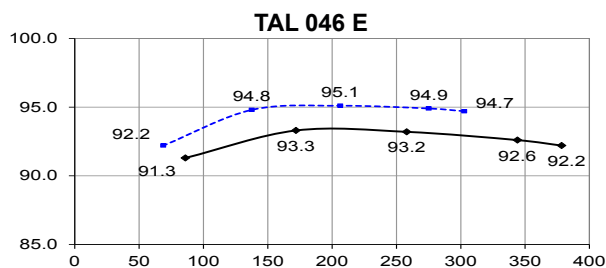
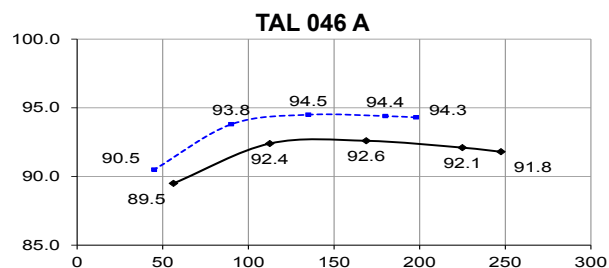

**Reactances (%). Time constants (ms) - Class H / 480 V**

	A	B	C	D	E	F	G	H
<b>Kcc</b> Short-circuit ratio	0.37	0.34	0.36	0.33	0.35	0.4	0.43	0.43
<b>Xd</b> Direct-axis synchro. reactance unsaturated	326	362	355	386	361	335	309	303
<b>Xq</b> Quadrature-axis synchro. reactance unsaturated	166	185	181	197	184	171	157	154
<b>T'do</b> No-load transient time constant	1956	1956	1983	1983	2018	2033	2072	2093
<b>X'd</b> Direct-axis transient reactance saturated	16.6	18.5	17.9	19.4	17.9	16.5	14.9	14.5
<b>T'd</b> Short-circuit transient time constant	100	100	100	100	100	100	100	100
<b>X''d</b> Direct-axis subtransient reactance saturated	13.3	14.8	14.3	15.5	14.3	13.2	11.9	11.6
<b>T''d</b> Subtransient time constant	10	10	10	10	10	10	10	10
<b>X''q</b> Quadrature-axis subtransient reactance saturated	17	18.9	18.1	19.7	18	16.4	14.7	14.2
<b>Xo</b> Zero sequence reactance	0.69	0.77	0.74	0.81	0.74	0.68	0.62	0.6
<b>X2</b> Negative sequence reactance saturated	15.2	16.9	16.2	17.6	16.2	14.8	13.3	12.9
<b>Ta</b> Armature time constant	15	15	15	15	15	15	15	15

**Other class H / 480 V data**

<b>io (A)</b> No-load excitation current SHUNT/AREP	0.94	0.94	1.01	1.01	1.03	1.1	1.1	1.06
<b>ic (A)</b> On-load excitation current SHUNT/AREP	3.46	3.79	3.91	4.21	4.03	3.91	3.69	3.56
<b>uc (V)</b> On-load excitation voltage SHUNT/AREP	49	53.6	38.3	41.1	56.7	45.5	42.9	41.3
<b>ms</b> Response time ( $\Delta U = 20\%$ transient)	500	500	500	500	500	500	500	500
<b>kVA</b> Start ( $\Delta U = 20\%$ cont. or $\Delta U = 30\%$ trans.) SHUNT*	376	376	446	448	532	534	665	742
<b>kVA</b> Start ( $\Delta U = 20\%$ cont. or $\Delta U = 30\%$ trans.) AREP*	450	450	537	536	639	640	798	889
<b>%</b> Transient $\Delta U$ (on-load 4/4) SHUNT - P.F.: 0.8 <sub>LAG</sub>	17.6	19	18.5	19.6	18.5	19.1	17.8	17.4
<b>%</b> Transient $\Delta U$ (on-load 4/4) AREP - P.F.: 0.8 <sub>LAG</sub>	15.5	16.7	16.3	17.3	16.7	17.2	16	15.7
<b>W</b> No-load losses	4522	4522	4958	4958	5412	5935	6673	6978
<b>W</b> Heat dissipation	15376	17830	19674	22244	21910	22085	23012	23141

\* P.F. = 0.6

Transient voltage variation 480 V - 60 Hz

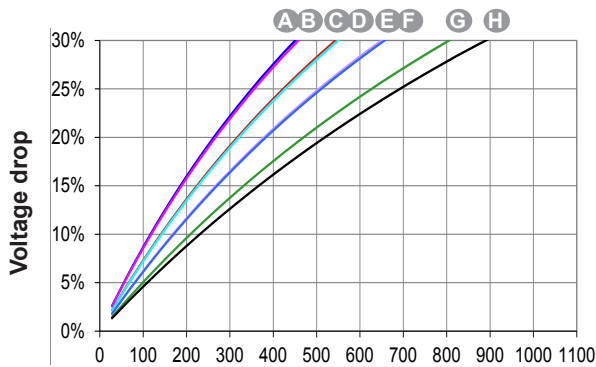

Phase loading (SHUNT) - kVA at P.F. = 0.8

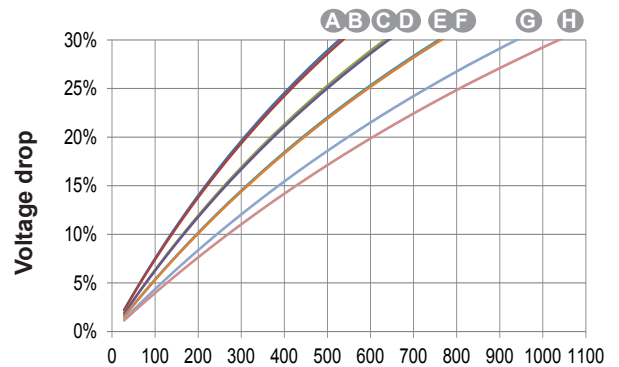

Phase loading (AREP) - kVA at P.F. = 0.8

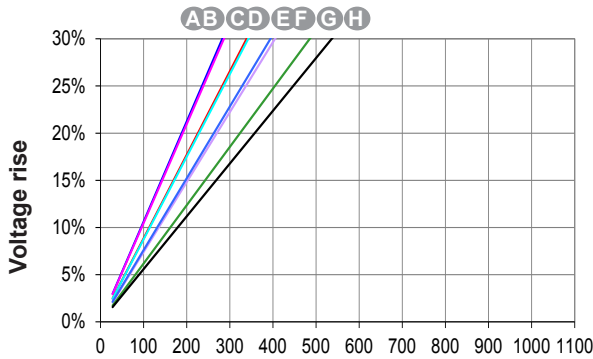

Load shedding (SHUNT) - kVA at P.F. = 0.8

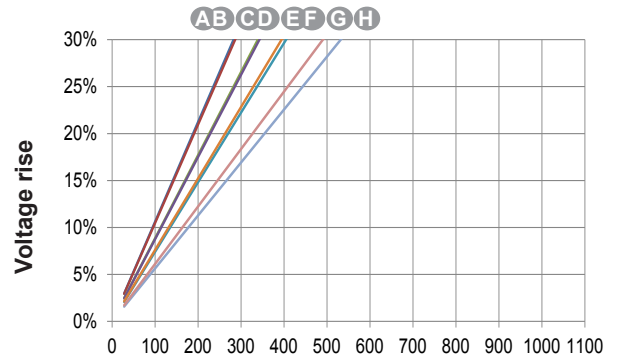

Load shedding (AREP) - kVA at P.F. = 0.8

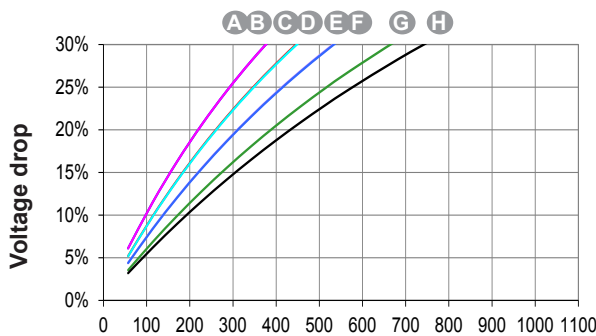

Motor starting (SHUNT)  
Locked rotor kVA at P.F. = 0.6

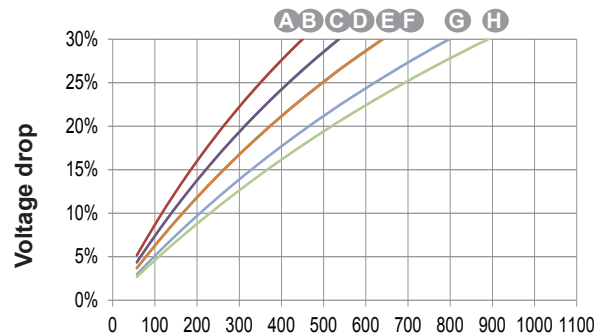

Motor starting (AREP)  
Locked rotor kVA at P.F. = 0.6

- 1) For a starting P.F. other than 0.6, the starting kVA must be multiplied by  $K = \text{Sine P.F.} / 0.8$
- 2) For voltages other than 480V (Y), 277V ( $\Delta$ ), 240V (YY) at 60 Hz, then kVA must be multiplied by  $(480/U)^2$  or  $(277/U)^2$  or  $(240/U)^2$ .

3-phase short-circuit curves at no load and rated speed (star connection Y)

**TAL 046 A**

Symmetrical —  
Asymmetrical - - -

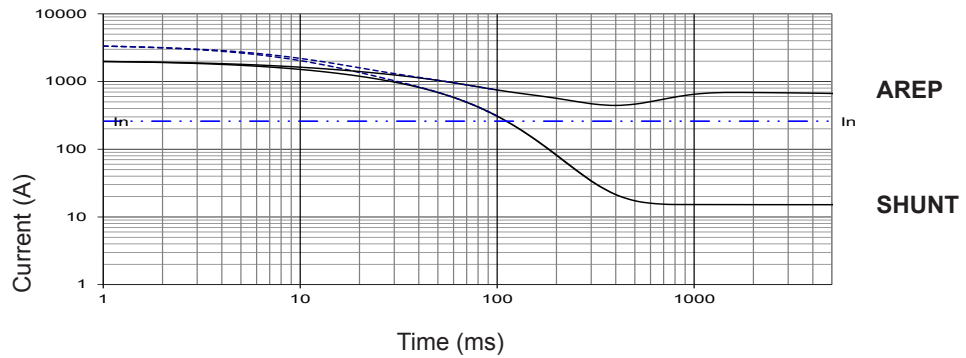

**TAL 046 B**

Symmetrical —  
Asymmetrical - - -

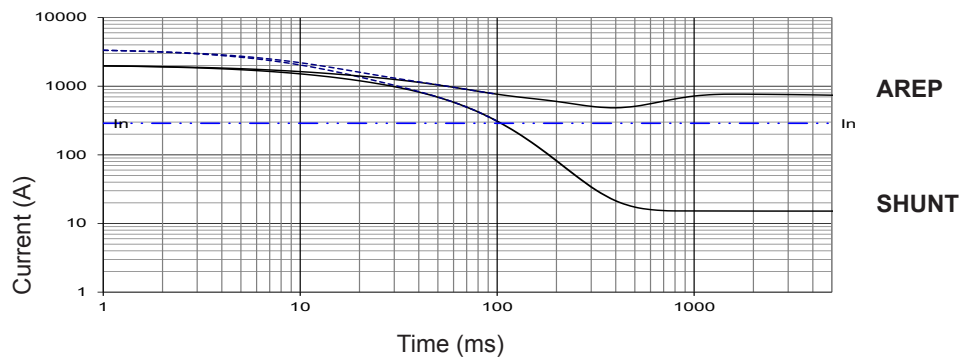

**TAL 046 C**

Symmetrical —  
Asymmetrical - - -

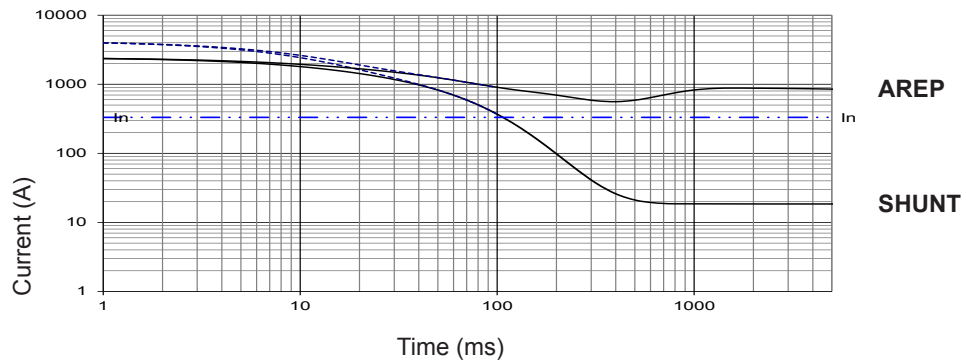

**TAL 046 D**

Symmetrical —  
Asymmetrical - - -

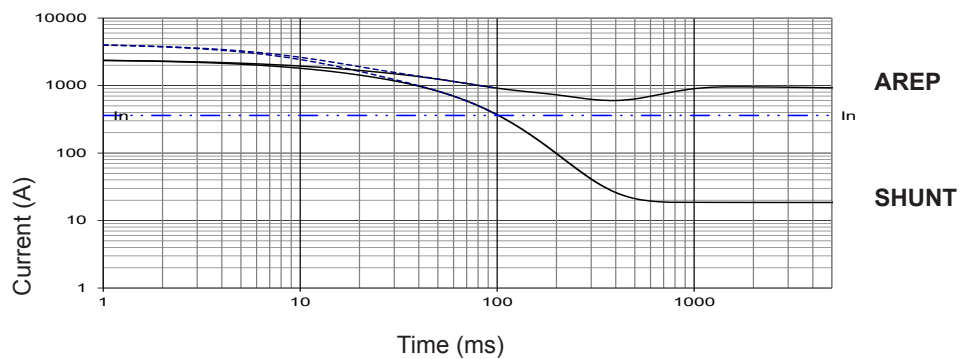

**Influence due to connection**

For (Δ) connection, use the following multiplication factor:  
- Current value x 1.732.

3-phase short-circuit curves at no load and rated speed (star connection Y)

**TAL 046 E**

Symmetrical —  
Asymmetrical - - -

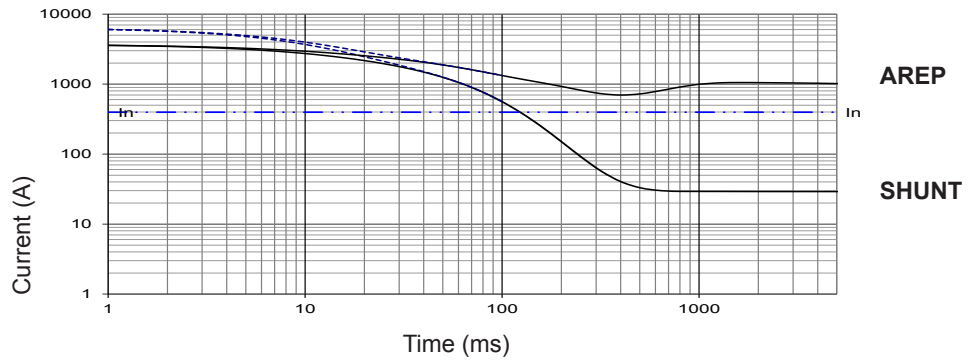

**TAL 046 F**

Symmetrical —  
Asymmetrical - - -

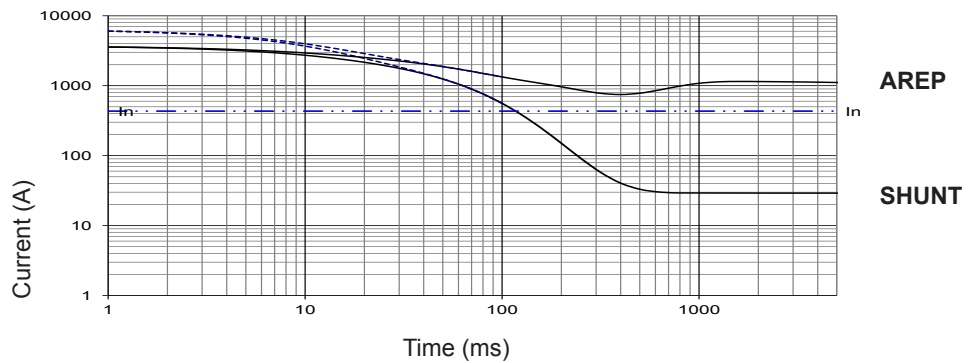

**TAL 046 G**

Symmetrical —  
Asymmetrical - - -

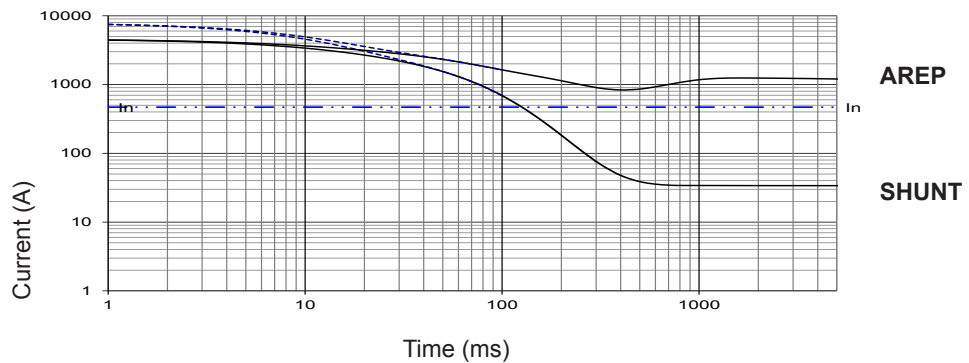

**TAL 046 H**

Symmetrical —  
Asymmetrical - - -

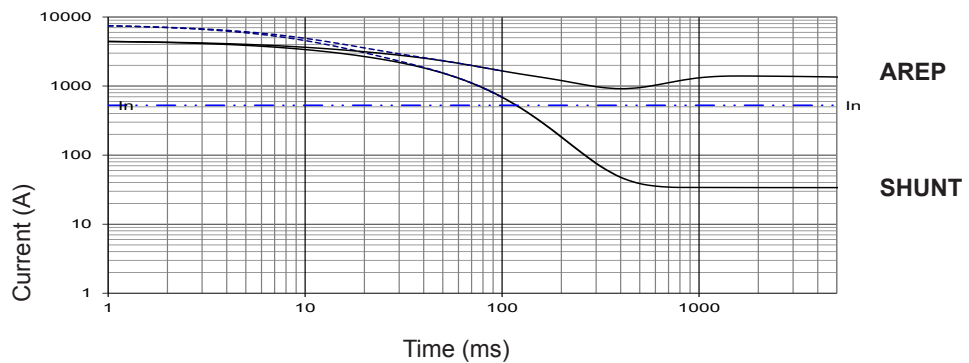

**Influence due to short-circuit**

Curves are based on a three-phase short-circuit. For other types of short-circuit, use the following multiplication factors.

	3 - phase	2 - phase L / L	1 - phase L / N
Instantaneous (max.)	1	0.87	1.3
Continuous	1	1.5	2.2
Maximum duration		1.5	

Single bearing general arrangement

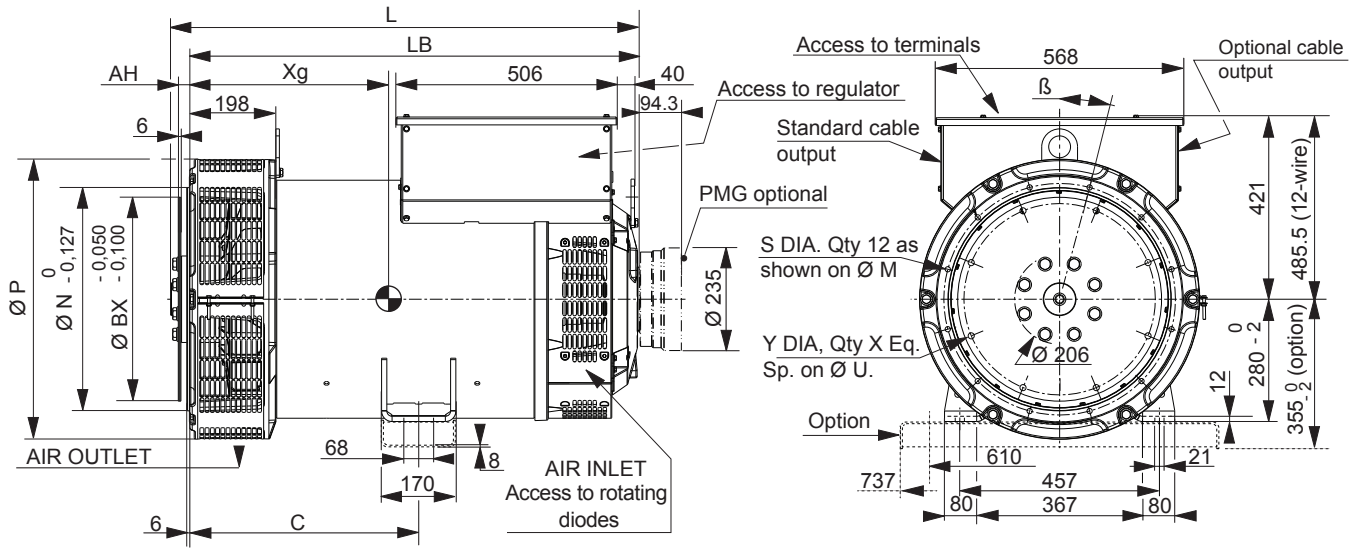

Dimensions (mm) and weight					
Type	L without PMG	LB	Xg	C	Weight (kg)
TAL 046 A	944**/935	892	408	429	569
TAL 046 B	944**/935	892	414	429	599
TAL 046 C	944**/935	892	423	429	674
TAL 046 D	944**/935	892	423	429	682
TAL 046 E	989**/980	937	445	429	754
TAL 046 F	989**/980	937	445	429	754
TAL 046 G*	1084**/1075	1032	493	525	888
TAL 046 H*	1084**/1075	1032	493	525	888

Coupling				
Flex plate	11 1/2	14	18	
Flange S.A.E 3	X			
Flange S.A.E 2	X			
Flange S.A.E 1	X	X		
Flange S.A.E 1/2		X		
Flange S.A.E 0		X	X	

\* Shaft height = 355 mm optional  
 \*\* Dimensions with SAE 11 1/2

Flange (mm)					
S.A.E.	P	N	M	S	β °
3	641	409.575	428.625	11	15°
2	641	447.675	466.725	11	15°
1	641	511.175	530.225	12	15°
1/2	713	584.2	619.125	14	15°
0	713	647.7	679.45	14	11° 15'

Flex plate (mm)					
S.A.E.	BX	U	X	Y	AH
11 1/2	352.42	333.38	8	11	39.6
14	466.72	438.15	8	14	25.4
18***	571.5	542.92	6	17	15.7

\*\*\* Option

Torsional data

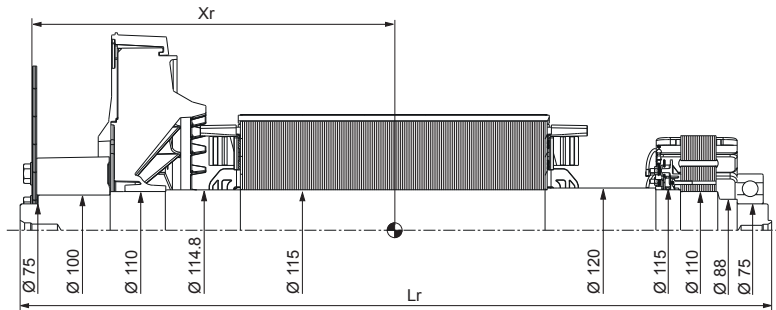

Centre of gravity: Xr (mm), Rotor length: Lr (mm), Weight: M (kg), Moment of inertia: J (kgm²): (4J = MD²)								
Type	Flex plate S.A.E. 11 1/2				Flex plate S.A.E. 14			
	Xr	Lr	M	J	Xr	Lr	M	J
TAL 046 A	413	923	243	2.46	401	923	244	2.62
TAL 046 B	413	923	243	2.46	401	923	244	2.62
TAL 046 C	420	923	255	2.64	408	923	256	2.8
TAL 046 D	420	923	255	2.64	408	923	256	2.8
TAL 046 E	460	968	304	3.28	448	968	305	3.44
TAL 046 F	460	968	304	3.28	448	968	305	3.44
TAL 046 G	508	1063	358	3.97	497	1063	359	4.13
TAL 046 H	508	1063	358	3.97	497	1063	359	4.13

NOTE : Dimensions are for information only and may be subject to modifications. The torsional analysis of the transmission is imperative. All values are available upon request.



**LEROY-SOMER**<sup>™</sup>

[www.leroy-somer.com/epg](http://www.leroy-somer.com/epg)

[Linkedin.com/company/Leroy-Somer](https://www.linkedin.com/company/Leroy-Somer)  
[Twitter.com/Leroy\\_Somer\\_en](https://twitter.com/Leroy_Somer_en)  
[Facebook.com/LeroySomer.Nidec.en](https://www.facebook.com/LeroySomer.Nidec.en)  
[YouTube.com/LeroySomerOfficiel](https://www.youtube.com/LeroySomerOfficiel)



***Nidec***  
**All for dreams**

© Nidec 2017. The information contained in this brochure is for guidance only and does not form part of any contract. The accuracy cannot be guaranteed as Nidec have an ongoing process of development and reserve the right to change the specification of their products without notice.

Moteurs Leroy-Somer SAS. Siège : Bd Marcellin Leroy, CS 10015, 16915 Angoulême Cedex 9, France.  
Capital social : 65 800 512 €, RCS Angoulême 338 567 258.

# DSE7310/20

## AUTO START & AUTO MAINS FAILURE CONTROL MODULES

### FEATURES



The DSE7310 is an Auto Start Control Module and the DSE7320 is an Auto Mains (Utility) Failure Control Module suitable for a wide variety of single, diesel or gas, gen-set applications.

Monitoring an extensive number of engine parameters, the modules will display warnings, shutdown and engine status information on the back-lit LCD screen, illuminated LEDs, remote PC and via SMS text alerts (with external modem).

The DSE7320 will also monitor the mains (utility) supply. The modules include USB, RS232 and RS485 ports as well as dedicated DSENet® terminals for system expansion.

Both modules are compatible with electronic (CAN) and non-electronic (magnetic pick-up/alternator sensing) engines and offer an extensive number of flexible inputs, outputs and extensive engine protections so the system can be easily adapted to meet the most demanding industry requirements.

The extensive list of features includes enhanced event and performance monitoring, remote communications, PLC functionality and dual mutual standby (DSE7310 only) to reduce engine wear.

The modules can be easily configured using the DSE Configuration Suite PC software. Selected front panel editing is also available.

### ENVIRONMENTAL TESTING STANDARDS

#### ELECTRO-MAGNETIC COMPATIBILITY

BS EN 61000-6-2  
EMC Generic Immunity Standard for the Industrial Environment  
BS EN 61000-6-4  
EMC Generic Emission Standard for the Industrial Environment

#### ELECTRICAL SAFETY

BS EN 60950  
Safety of Information Technology Equipment, including Electrical Business Equipment

#### TEMPERATURE

BS EN 60068-2-1  
Ab/Ae Cold Test -30 °C  
BS EN 60068-2-2  
Bb/Be Dry Heat +70 °C

#### VIBRATION

BS EN 60068-2-6  
Ten sweeps in each of three major axes  
5 Hz to 8 Hz @ +/-7.5 mm,  
8 Hz to 500 Hz @ 2 gn

#### HUMIDITY

BS EN 60068-2-30  
Db Damp Heat Cyclic 20/55 °C @ 95% RH 48 Hours  
BS EN 60068-2-78  
Cab Damp Heat Static 40 °C @ 93% RH 48 Hours

#### SHOCK

BS EN 60068-2-27  
Three shocks in each of three major axes  
15 gn in 11 mS

#### DEGREES OF PROTECTION PROVIDED BY ENCLOSURES

BS EN 60529  
IP65 - Front of module when installed into the control panel with the supplied sealing gasket.

## COMPREHENSIVE FEATURE LIST TO SUIT A WIDE VARIETY OF GEN-SET APPLICATIONS

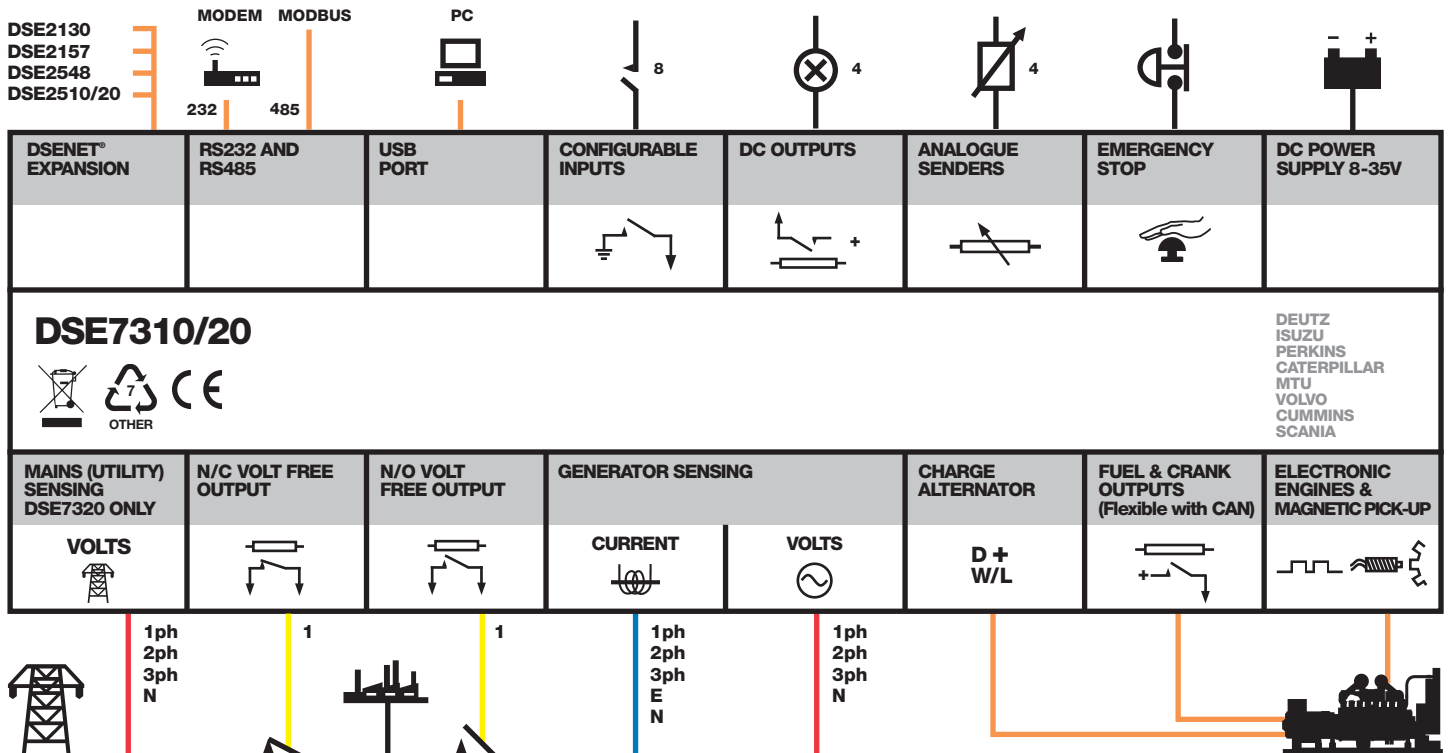



# DSE7310/20

## AUTO START & AUTO MAINS FAILURE CONTROL MODULES

### FEATURES



#### DSE7310



#### KEY FEATURES

- 4-Line back-lit LCD text display
- Five key menu navigation
- Front panel editing with PIN protection
- Customisable status screens
- Power save mode
- Support for up to three remote display units
- 9 configurable inputs
- 8 configurable outputs
- Flexible sender inputs
- Configurable timers and alarms
- 3 configurable maintenance alarms
- Multiple date and time scheduler
- Configurable event log (250)
- Tier 4 CAN engine support
- Integral PLC editor
- Easy access diagnostic page
- CAN and Magnetic Pick-up/Alt. sensing
- Fuel usage monitor and low fuel alarms
- Charge alternator failure alarm
- Manual speed control (on compatible CAN engines)
- Manual fuel pump control
- Engine exerciser
- "Protections disabled" feature
- kW & kV Ar protection

#### DSE7320



- Reverse power (kW & kV Ar) protection
- LED and LCD alarm indication
- Power monitoring (kW h, kV Ar, kV A h, kV Ar h)
- Load switching (load shedding and dummy load outputs)
- Automatic load transfer (DSE7320)
- Unbalanced load protection
- Independent Earth Fault trip
- True dual mutual standby with load balancing timer (DSE7310 only)
- USB connectivity
- Backed up real time clock
- Fully configurable via DSE Configuration Suite PC software
- Configurable display languages
- Remote SCADA monitoring via DSE Configuration Suite PC software
- User selectable RS232 and RS485 communications
- Configurable Gencomm pages
- Advanced SMS messaging (additional external modem required)
- Start & stop capability via SMS messaging
- Additional display screens to help with modem diagnostics
- Idle control for starting & stopping.
- DSENet® expansion compatible

#### KEY BENEFITS

- 132 x 64 pixel ratio display for clarity
- Real-time clock provides accurate event logging
- Multiple date and time scheduler
- Set maintenance periods can be configured to maintain optimum engine performance
- Ethernet communications (via DSE860/865 modules), provides advanced remote monitoring at low cost
- Modules can be integrated into building management systems (BMS)
- Increased input and output expansion capability via DSENet®
- Licence-free PC software
- IP65 rating (with supplied gasket) offers increased resistance to water ingress
- PLC editor allows user configurable functions to meet specific application requirements

### SPECIFICATION

#### DC SUPPLY

**CONTINUOUS VOLTAGE RATING**  
8 V to 35 V Continuous

#### CRANKING DROPOUTS

Able to survive 0 V for 50 mS, providing supply was at least 10 V before dropout and supply recovers to 5 V. This is achieved without the need for internal batteries. LEDs and backlight will not be maintained during cranking.

#### MAXIMUM OPERATING CURRENT

340 mA at 12 V, 160 mA at 24 V

#### MAXIMUM STANDBY CURRENT

160 mA at 12 V, 80 mA at 24 V

#### CHARGE FAIL/EXCITATION RANGE

0 V to 35 V

#### MAINS (UTILITY) DSE7320 ONLY

**VOLTAGE RANGE**  
15 V - 333 V AC (L-N)

#### FREQUENCY RANGE

3.5 Hz to 75 Hz

#### OUTPUTS

##### OUTPUT A (FUEL)

15 A DC at supply voltage

##### OUTPUT B (START)

15 A DC at supply voltage

##### OUTPUTS C & D

8 A 250 V (Volt free)

##### AUXILIARY OUTPUTS E,F,G,H

2 A DC at supply voltage

#### GENERATOR

##### VOLTAGE RANGE

15 V - 333 V AC (L-N)

##### FREQUENCY RANGE

3.5 Hz to 75 Hz

##### MAGNETIC PICK UP

##### VOLTAGE RANGE

+/- 0.5 V to 70 V

##### FREQUENCY RANGE

10,000 Hz (max)

#### DIMENSIONS

##### OVERALL

240 mm x 181 mm x 42 mm  
9.4" x 7.1" x 1.6"

##### PANEL CUT-OUT

220 mm x 160 mm  
8.7" x 6.3"

##### MAXIMUM PANEL THICKNESS

8 mm  
0.3"

### RELATED MATERIALS

#### TITLE

DSE7310 Installation Instructions  
DSE7320 Installation Instructions  
DSE7200/7300 Quick Start Guide  
DSE7200/7300 Operator Manual  
DSE7200/7300 Configuration Suite PC Manual

#### PART NO'S

053-028  
053-029  
057-101  
057-074  
057-077

### DEEP SEA ELECTRONICS PLC UK

Highfield House, Hunmanby Industrial Estate, Hunmanby YO14 0PH  
**TELEPHONE** +44 (0) 1723 890099 **FACSIMILE** +44 (0) 1723 893303  
**EMAIL** sales@deepseapl.com **WEBSITE** www.deepseapl.com

### DEEP SEA ELECTRONICS INC USA

3230 Williams Avenue, Rockford, IL 61101-2668 USA  
**TELEPHONE** +1 (815) 316 8706 **FACSIMILE** +1 (815) 316 8708  
**EMAIL** sales@deepseausa.com **WEBSITE** www.deepseausa.com